

Received: 15 May 2016  
Accepted: 25 June 2016

# ANALYSE OF THE PRODUCTION OF A SPECIFIC ENTERPRISE WITH A FOCUS ON THE IDENTIFICATION OF BOTTLENECK

**Veronika Krešáková**

Technical University of Kosice, Faculty BERG, Institute of Logistics, Park Komenskeho 14, 043 84 Kosice, Slovakia, veronika.kresakova@gmail.com

**Keywords:** logistics, manufacturing process, analyse, designing, bottleneck

**Abstract:** Each enterprise is based on processes, either productive or non-productive. Productive processes are made by automatic or semi-automatic production lines or by manpower. This article deals with a semi-automatic production line within a specific company. It aims to show possibilities to locate the bottleneck. An enterprise can also represent an international company, which aims to design and produce high-tech systems and components for the automotive sector. The result of the production process is the “component A”.

## 1 Introduction

The material flow of the “component A” depends on the reference that is currently produced. Some pre-assembly inputs are made directly in the enterprise and some are obtained by a purchase from the suppliers, depending on the “Make or Buy” decision. The production line obeys the “One piece flow” and the FIFO

method, meaning that the requirements are dealt in the same order, in which they entered the production line. The bottlenecks are being observed within the production process. 100-percent feedback, which is mediated by the DMC codes, is obeyed at each output. The production process (Figure 1) runs non-stop [1].

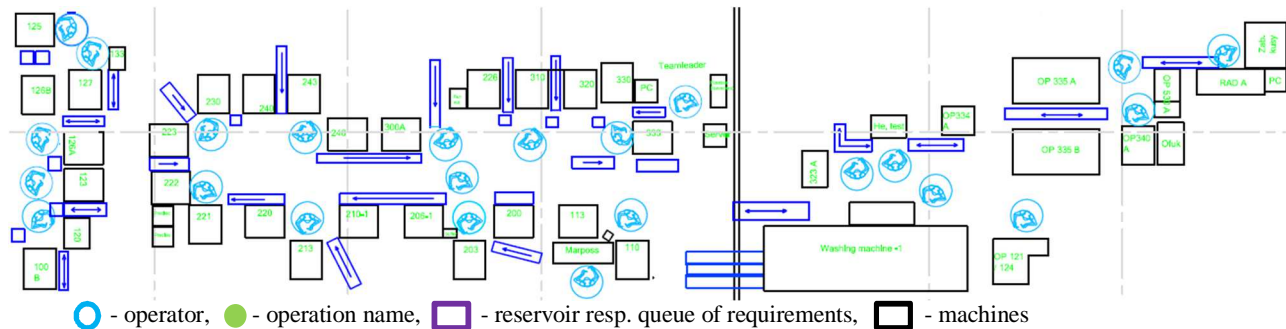

Figure 1 Production line

The production line consists of the following machines, which occur in the line repeatedly:

- Washer and dryer

Everything entering the production process has to be washed, resp. degreased, in order to meet the requirements of the customer and the production process itself. All the components are washed in the chemical A, which is used for the degrease process and then in the chemical B, which secures the surface features of the components, according to the following requirements of the production process. Then, the components are dried with a 110°C hot air.

- Welding machine

The production process requires the welding machines with the laser welding.

- Press machine

In the production process, there are used electrical press machines (pressure test with air – 5 bar, pressure test with helium – 10 bar).

- Measuring device

The quality controls within the process are secured by the cameras (measure of deviation, end of line test). The final control of the product is made by dynamic of static tests, according to the customer’s wish.

## 2 Bottleneck identification possibilities

The first requirement in the process of finding the bottleneck is to know the production process and the time length of individual operations. According to the analysis of the enterprise, it is possible to create a formal version of the material flow in the production line, which also represents the output of the current-state analysis [2] and

**ANALYSE OF THE PRODUCTION OF A SPECIFIC ENTERPRISE WITH A FOCUS ON THE IDENTIFICATION OF BOTTLENECK**

Veronika Krešáková

a tool for the creation of block scheme of the simulation model [3]. This scheme shows the individual operation time lengths, queue limitations and the production lines

inputs. The following picture (Figure 2) shows an example of the scheme.

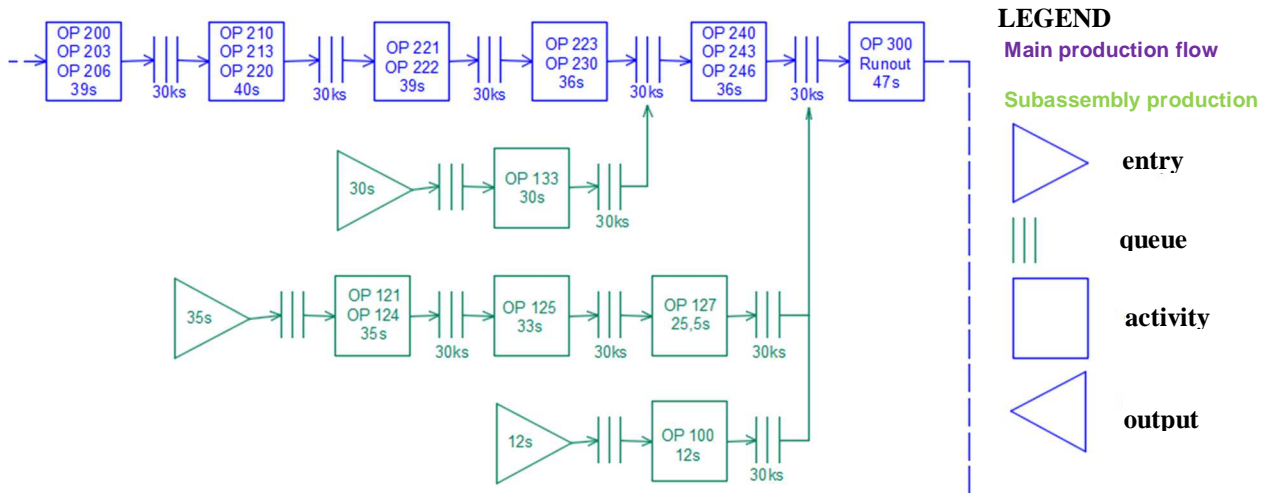

Figure 2 Example of the material flow of the production line

Based on the scheme (Figure 3), it is possible to access the following step, creation of the block scheme of the production line simulation model. One part of the

block scheme can be seen in the following picture. The blocks that are used are found in the Item and Plotter library of the simulation program ExtendSim [4].

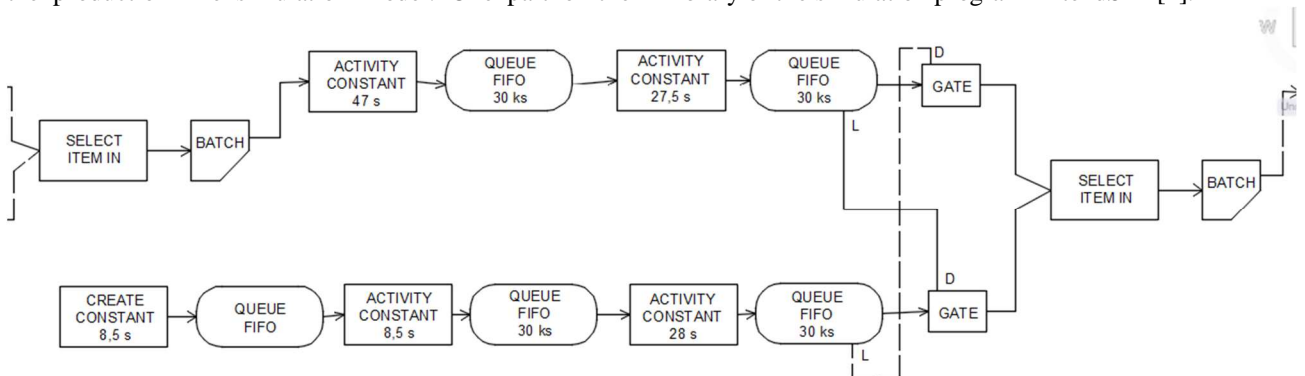

Figure 3 Example of the block scheme of the simulation model of the production line

It is possible to create a simulation model based on the whole simulation model block scheme. The simulation model will simulate the course of the production process, based on which we will be able to find out the usage of the individual machines, resp. it will be possible to see which device has the longest queue in front of it. Such a place will be working on 100 percent and that is why we consider it a bottleneck.

Mapping of the value flow (value stream mapping - VSM) [5], based on the given information from the enterprise, is another method that describes the current state of the material and information flow of the "component A" production. VSM consists of two flows:

- Information flow (Figure 4)

The whole information flow works on the PULL system that begins with the arrival of the orders from the customers in a weekly period. These orders are recorded in PC&L area of the enterprise, which is the department of logistics. The logistics department plans the production process and moves the information further resp. plans the production plan as far as for the last operation of the production process. It gets the data from the production of the last operation retroactively. PC&L area ensures the ordering of the components from the suppliers on a weekly period. The supply of the components from the supplier and sales of the finished products takes place on a weekly period [1].

**ANALYSE OF THE PRODUCTION OF A SPECIFIC ENTERPRISE WITH A FOCUS ON THE IDENTIFICATION OF BOTTLENECK**  
 Veronika Krešáková

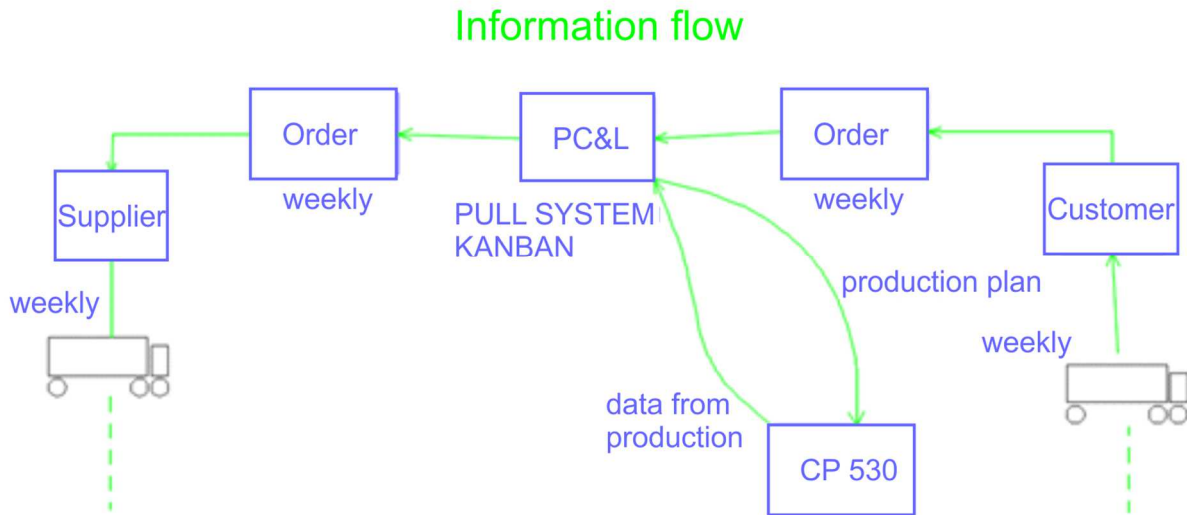

Figure 4 Example of the information flow from VSM

- Material flow (Figure 5)

It is a flow that describes the whole course of the production process, resulting in component A.

Every single operation of the production process has a defined [1]:

- Time of the operation cycle (C/T)
- Capacity of the machine (K)
- Number of the operators (O)

- Number of the changes (Z)
- Total capacity utilization (OEE – Overall equipment effectiveness)

Reservoir, resp. requirement queue is restricted to a maximum of 30 pieces of components, in which FIFO principle is adhered. There also are some reservoirs that have no restrictions [1].

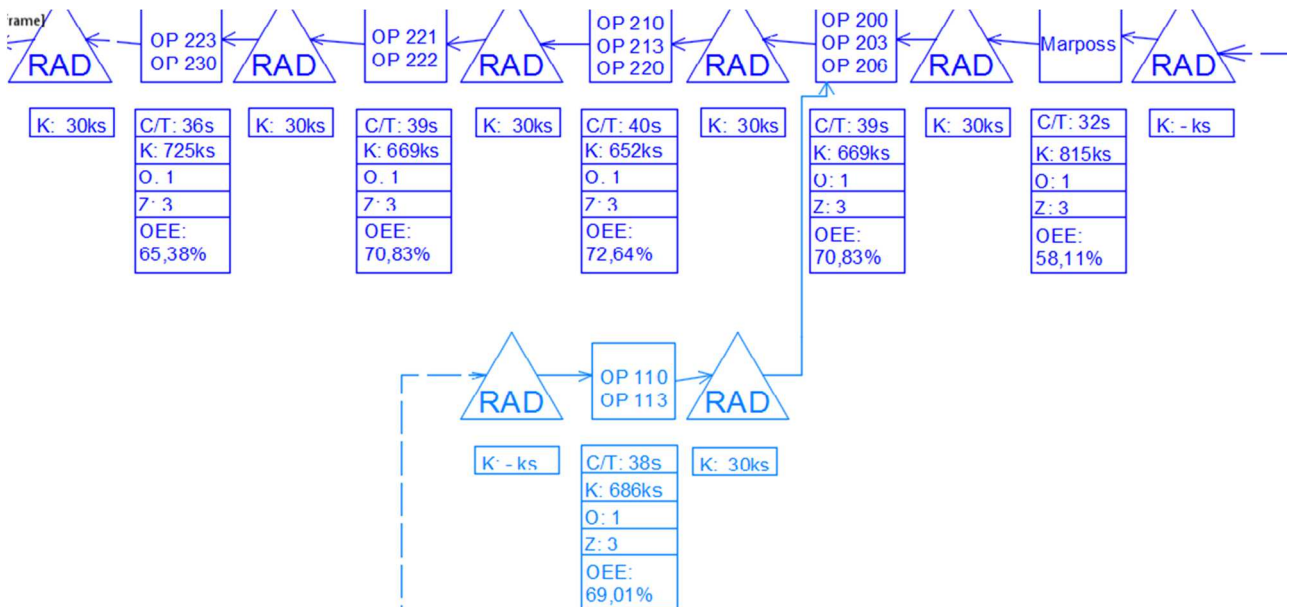

Figure 5 Example of the material flow from VSM

**Conclusions**

According to the calculated capacity of the machines and overall usage of their capacity, it is possible to construct the following graph (Figure 6).

**ANALYSE OF THE PRODUCTION OF A SPECIFIC ENTERPRISE WITH A FOCUS ON THE IDENTIFICATION OF BOTTLENECK**

Veronika Krešáková

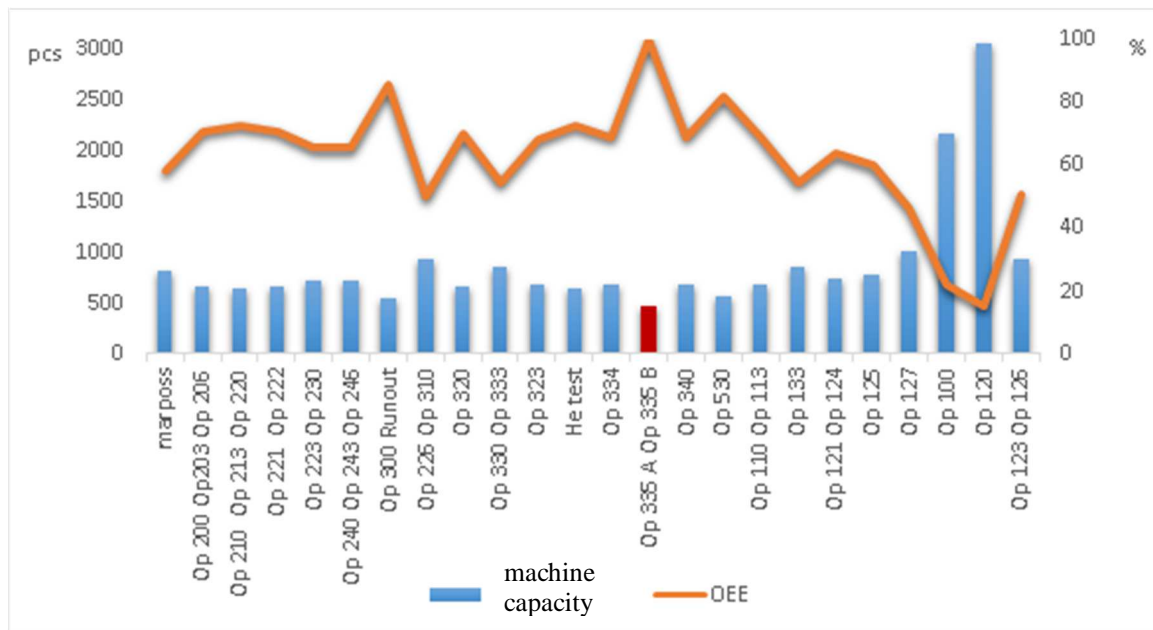

Figure 6 Identification of the bottleneck using the capacities of machines and their overall usage

The graph (Figure 6) concerns about the bottleneck, which is supported by the calculations of the machines capacity and its usage during the production of the component A. Operations OP 335 A and OP 335 B have lower machine capacity resp. they have the ability to produce the smallest number of components. The number of components served by this operation per one shift is approximately 474 pieces, whereas these two operations restrict the production process, because the capacity of other machines reaches its quadruple. The usage of the machines of these two operations is 100%, because it represents the bottleneck, therefore it has to operate non-stop. The output of the production process can only be as many components as can go through the bottleneck.

Based on the identification of the bottleneck, it is possible to consider the following solutions for the elimination of the bottleneck:

- reassessment of the fastest machine,
- reassessment of the row size,
- design of organization changes,
- increasing of the machine capacities.

## References

- [1] Internal materials of analysed company OMEGA, 2016. (Original in Slovak)
- [2] MADARÁSZ, L., BUČKO, M., ANDOGA, R.: *Systémová analýza a syntéza*, Košice, 2008. (Original in Slovak)
- [3] MALINDŽÁK, D., ŠINDLER, V.: *Modelovanie výrobných procesov*, Košice, 2001. (Original in Slovak)

[4] STRAKA, M.: *Simulácia diskretných systémov a simulačné jazyky*, Košice, 2005. (Original in Slovak)

[5] MAŠÍN, I.: *Mapování hodnotového toku ve výrobních procesech*. Liberec, 2003. (Original in Czech)

## Review process

Single-blind peer reviewed process by two reviewers.